



Custom Pilot Scale and Laboratory Equipment

We provide the tools you need – letting you concentrate on producing great science and new products. From bench-scale to pre-production our team of scientists and engineers can design and build the custom equipment you need.



C-Tech Innovation produces test-rigs and pilot scale equipment for academic and industrial clients in a wide range of areas including: Chemistry, chemical engineering, microbiology and materials science.

We talk your language – with a broad range of specialist scientists and engineers available, you can talk to someone who understands the requirements of your industry and can help develop the best solution for you. Tell us what, we'll work out how.

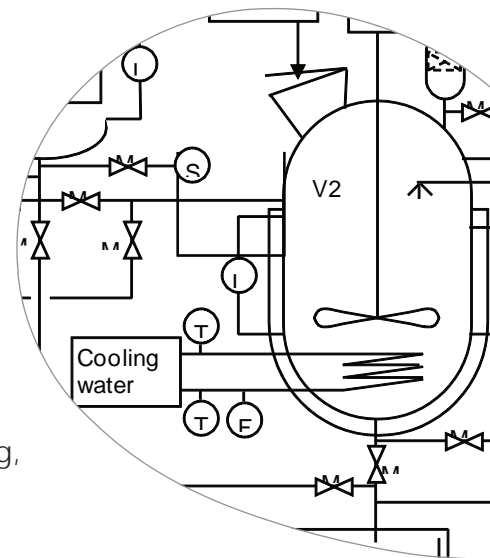

Our Services

- Design and build
- Automation and control
- Instrumentation and data acquisition
- Hazard studies and risk assessments
- Pressure equipment (PED compliant)
- Equipment suitable for hazardous areas
- CE marked equipment

Core Expertise

- Hazardous or difficult to handle materials and process conditions
- Corrosive solvents and ionic liquids
- Novel heating technologies and high temperature processes
- Electrochemistry
- Process and equipment integration

